

COOLANT INSPECTION

COO1O-03

HINT:

Check the coolant level when the engine is cold.

1. CHECK ENGINE COOLANT LEVEL AT RADIATOR RESERVOIR

The engine coolant level should be between the "LOW" and "FULL" lines at normal temperature (20°C(68°F)).

If low, check for leaks and add "TOYOTA Long Life Coolant" or equivalent up to the "FULL" line.

2. CHECK ENGINE COOLANT QUALITY

(a) Remove the radiator cap.

CAUTION:

To avoid the danger of being burned, do not remove the radiator cap while the engine and radiator are still hot, as fluid and steam can be blown out under pressure.

(b) There should not be any excessive deposits of rust or scale around the radiator cap or radiator filler hole, and the coolant should be free from oil.

If excessively dirty, clean the coolant passages and replace the coolant.

(c) Reinstall the radiator cap.

REPLACEMENT

CAUTION:

To avoid the danger of being burned, do not remove the radiator cap while the engine and radiator are still hot, as fluid and steam can be blown out under pressure.

1. REMOVE ENGINE UNDER COVER

2. DRAIN ENGINE COOLANT

(a) Remove the radiator cap.

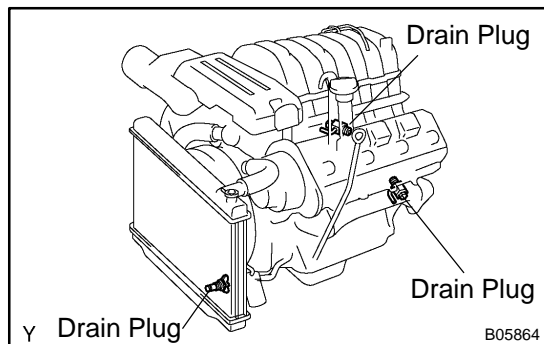

(b) Remove the 3 drain plugs on the engine and radiator, and drain the coolant.

(c) Close the 3 drain plugs.

Torque: 12.7 N·m (130 kgf·cm, 9 ft·lbf) for engine

3. REFILL WITH ENGINE COOLANT

(a) Slowly fill the system with coolant.

Capacity: 11.6 liters (12.3 US qts, 10.2 Imp. qts)

NOTICE:

Do not use plain water alone.

HINT:

- ◆ Use of improper coolants may damage the engine cooling system.
- ◆ Use "Toyota Super Long Life Coolant" or similar high quality ethylene glycol based non-silicate, non-amine, non-nitrite, and non-borate coolant with long-life hybrid organic acid technology.
- ◆ New Toyota vehicles are filled with Toyota Super Long Life Coolant (color is pink, premixed ethylene glycol concentration is approximately 50 % and freezing temperature is -35°C (-31°F)). When replacing the coolant, Toyota Super long Life Coolant is recommended.
- ◆ Observe the coolant level inside the radiator by pressing the inlet and outlet radiator hoses several times by hand. If the coolant level goes down, add the coolant.

(b) Install the radiator cap.

(c) Bleed the cooling system.

(1) Start the engine, and open the heater water valve.

(2) Maintain the engine speed at 2,000 - 2,500 rpm, and warm up the engine.

(d) Stop the engine, and wait until the engine coolant cools down.

(e) Refill coolant into the reservoir until it is "FULL".

4. CHECK FOR ENGINE COOLANT LEAKS

5. CHECK ENGINE COOLANT SPECIFIC GRAVITY CORRECTLY

6. REINSTALL ENGINE UNDER COVER

WATER PUMP COMPONENTS

CO01Q-11

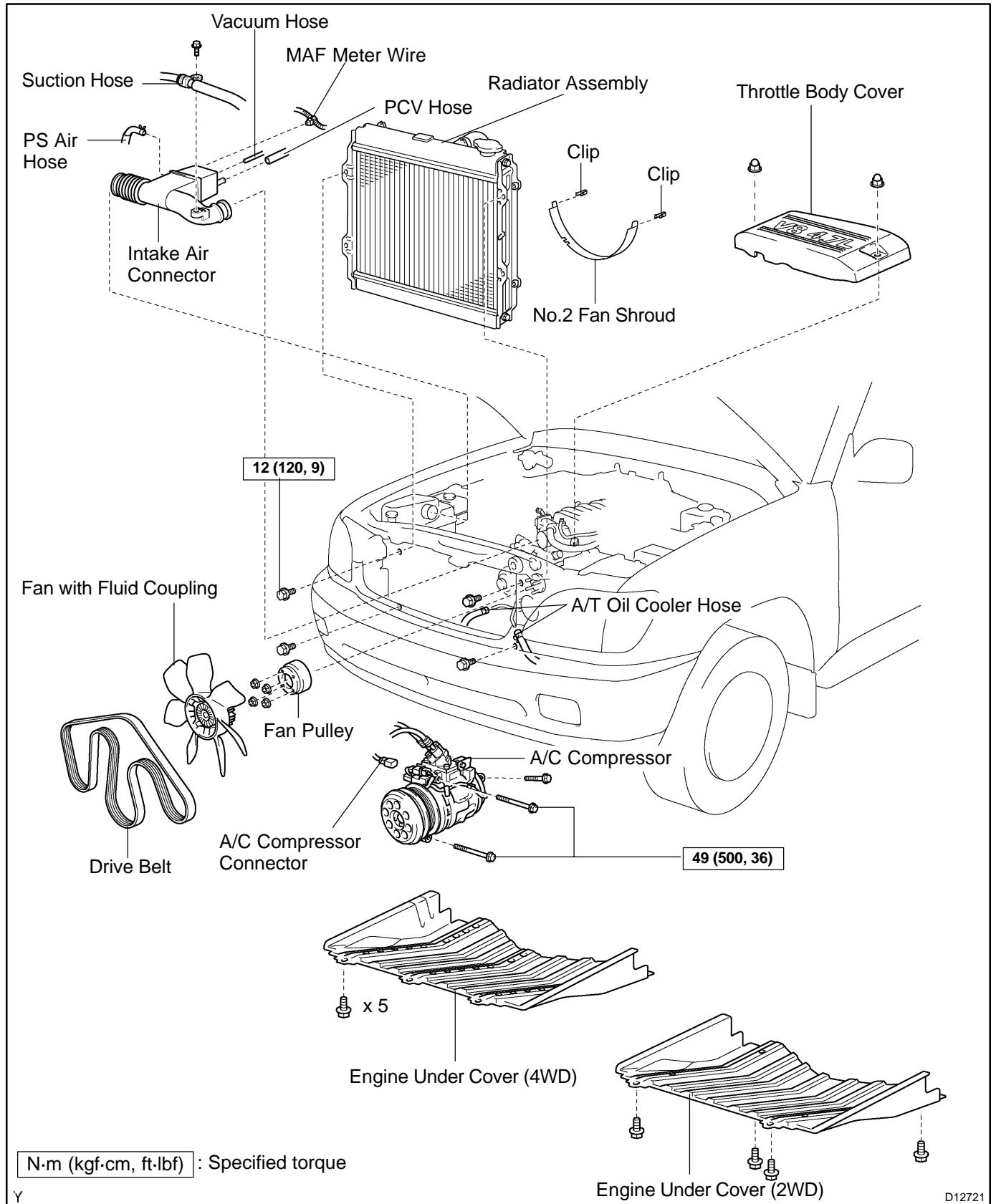

Y

D12721

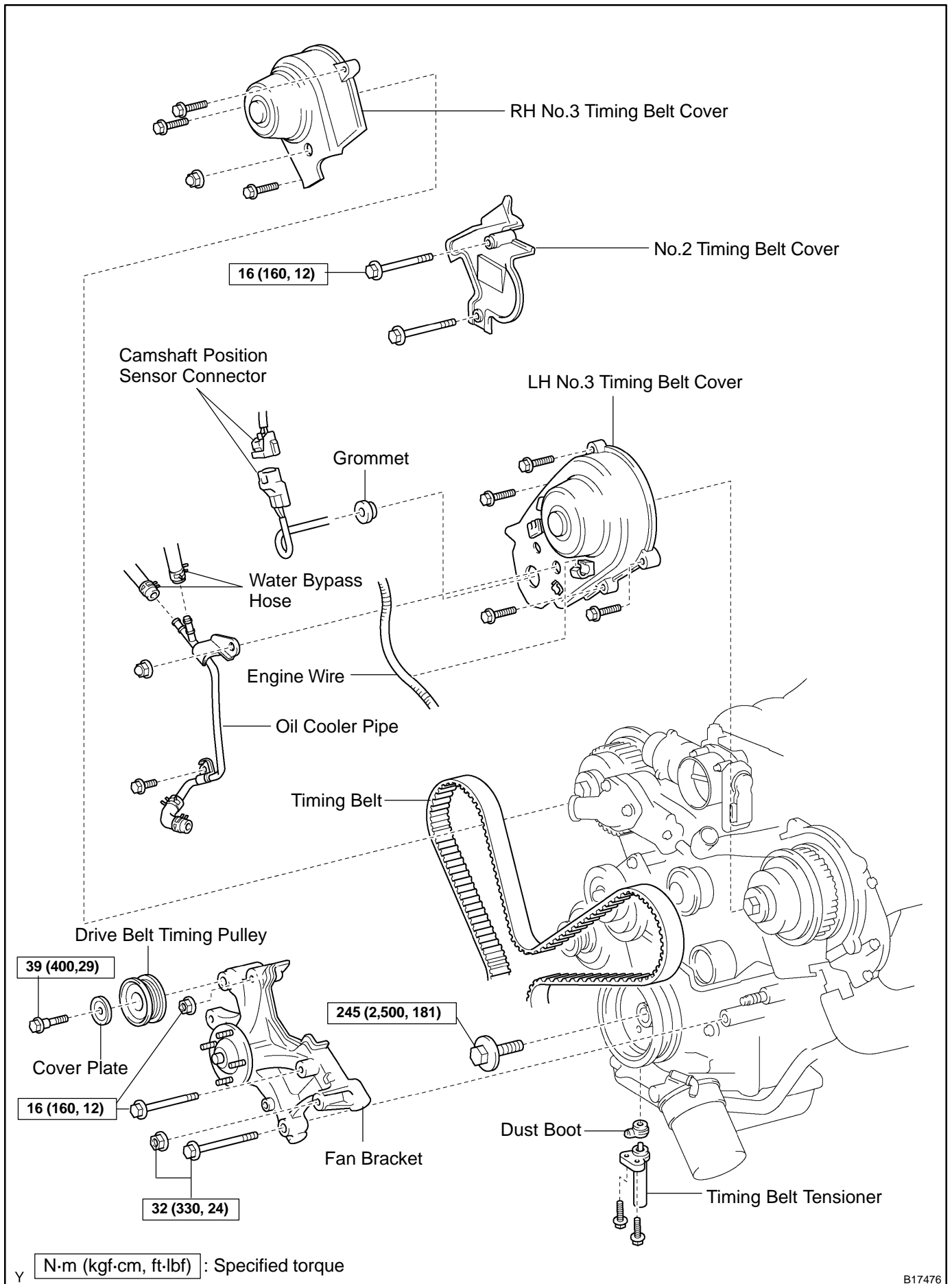

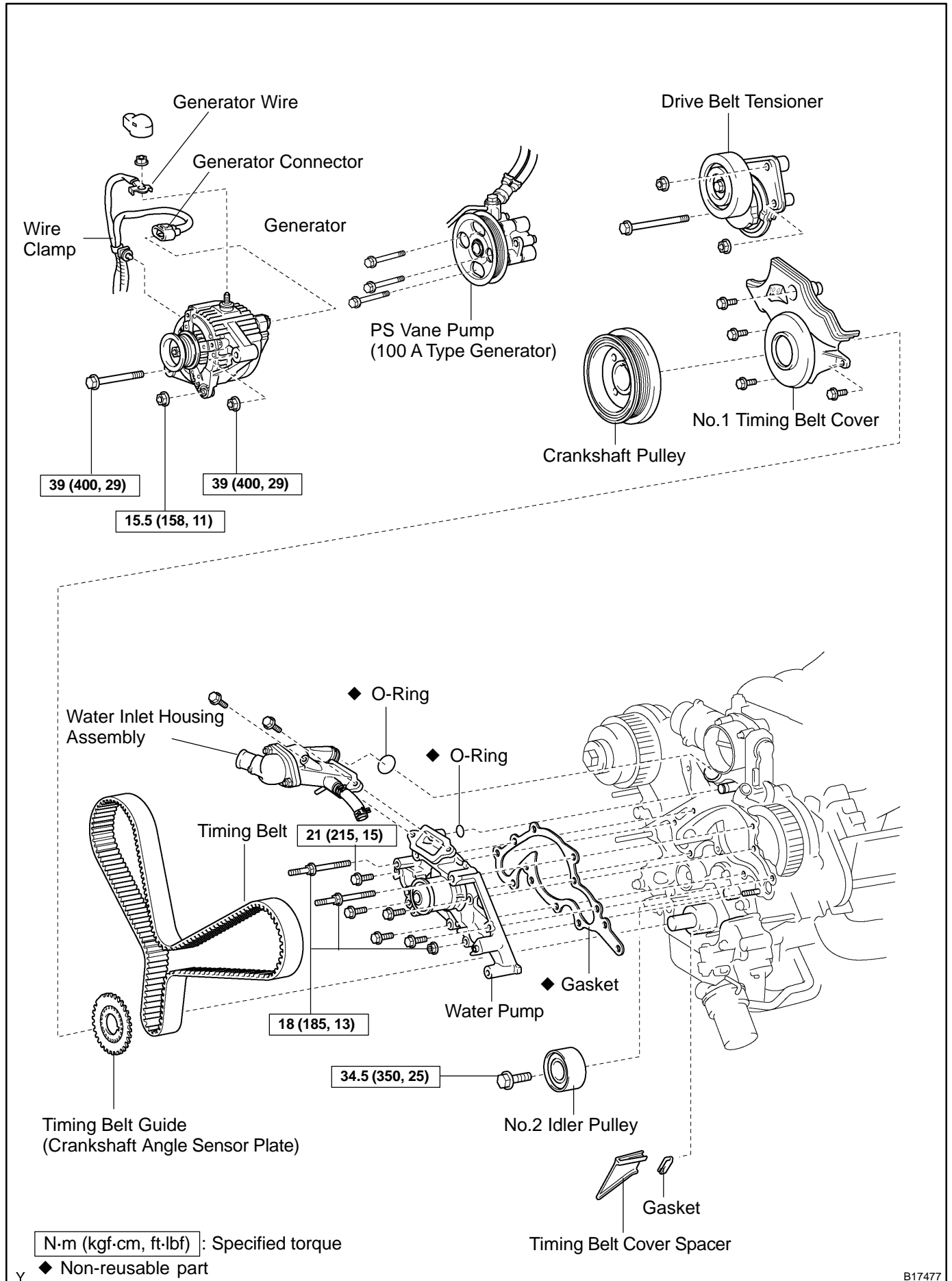

B17477

REMOVAL

1. DRAIN ENGINE COOLANT
2. REMOVE TIMING BELT (See page [EM-16](#))
3. REMOVE NO.2 IDLER PULLEY (See page [EM-16](#))

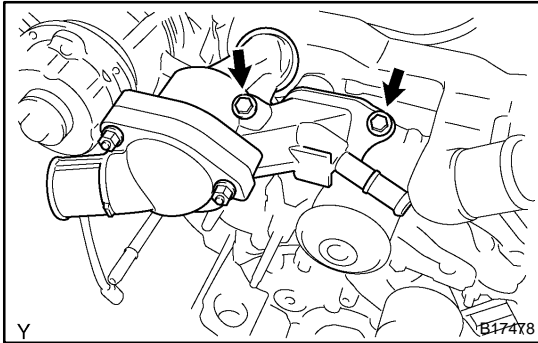

4. REMOVE WATER INLET AND INLET HOUSING ASSEMBLY

- (a) Disconnect the water bypass hose from the water inlet housing.
- (b) Remove the 2 bolts holding the water inlet housing to the water pump.
- (c) Disconnect the water inlet housing from the front water bypass joint, and remove the water inlet and inlet housing assembly.
- (d) Remove the O-ring from the water inlet housing.

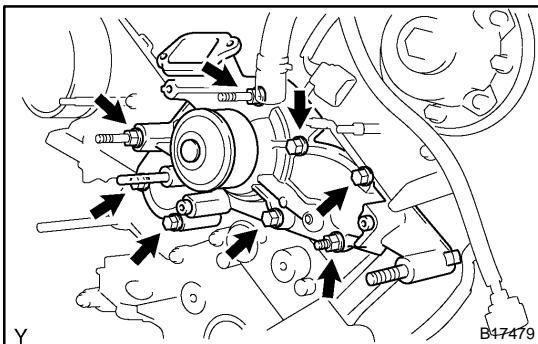

5. REMOVE WATER PUMP

- (a) Remove the 5 bolts, 2 stud bolts, nut, water pump and gasket.
- (b) Remove the O-ring from the water bypass pipe.

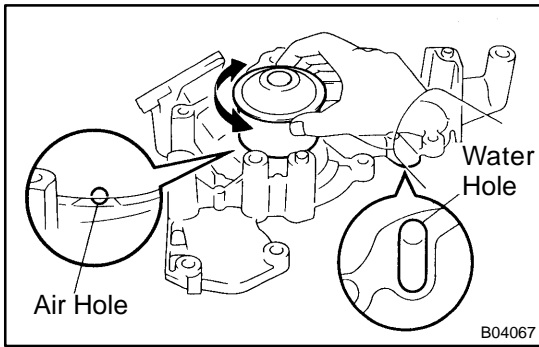

INSPECTION

1. INSPECT WATER PUMP

- (a) Visually check the air hole and water hole for coolant leakage.

If leakage is found, replace the water pump and timing belt.

- (b) Turn the pulley, and check that the water pump bearing moves smoothly and quietly.

If necessary, replace the water pump.

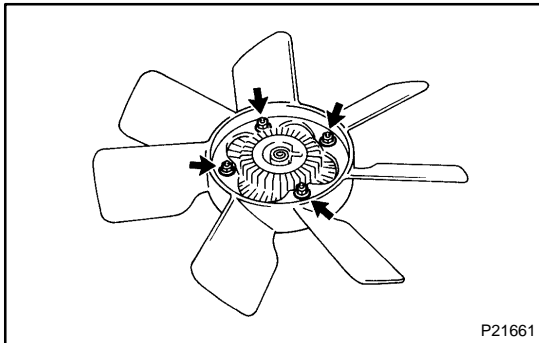

2. INSPECT FLUID COUPLING

- (a) Remove the 4 nuts and fan from the fluid coupling.

- (b) Check that the fluid coupling is not damaged and that no silicon oil leaks.

If necessary, replace the fluid coupling.

- (c) Reinstall the fan to the fluid coupling with the 4 nuts.

Torque: 5.4 N·m (55 kgf·cm, 47 in.-lbf)

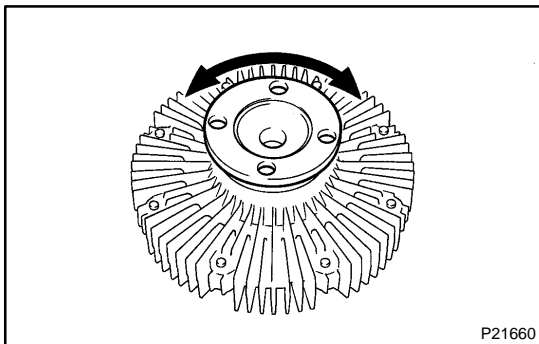

3. INSPECT FAN PULLEY BRACKET

Check the turning smoothness of the fan pulley.

If necessary, replace the pulley bracket.

4. INSPECT TIMING BELT COMPONENTS

(See page [EM-21](#))

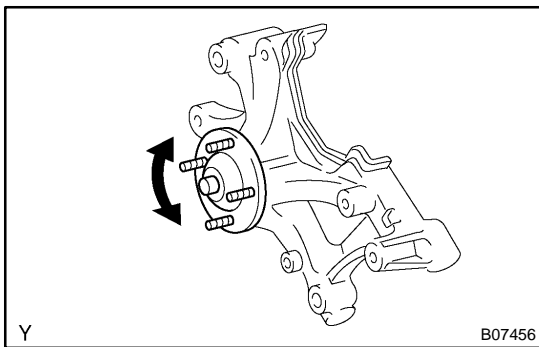

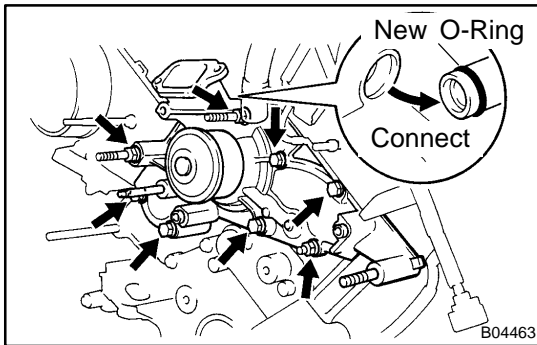

INSTALLATION

1. INSTALL WATER PUMP

- Install a new O-ring to the water bypass pipe end.
- Apply soapy water to the O-ring.
- Connect the water pump to the water bypass pipe end.
- Install the water pump and a new gasket with the 5 bolts, 2 stud bolts and nut. Uniformly tighten the bolts, stud bolts and nut in several passes.

Torque:

Bolt: 21 N·m (215 kgf·cm, 15 ft·lbf)

Stud bolt and nut: 18 N·m (185 kgf·cm, 13 ft·lbf)

2. INSTALL WATER INLET AND INLET HOUSING ASSEMBLY

- Remove any old packing (FIPG) material and be careful not to drop any oil on the contact surfaces of the water inlet housing and water pump.
 - ◆ Using a razor blade and gasket scraper, remove all the old packing (FIPG) material from the gasket surfaces and sealing groove.
 - ◆ Thoroughly clean all components to remove all the loose material.
 - ◆ Using a non-residue solvent, clean both sealing surfaces.

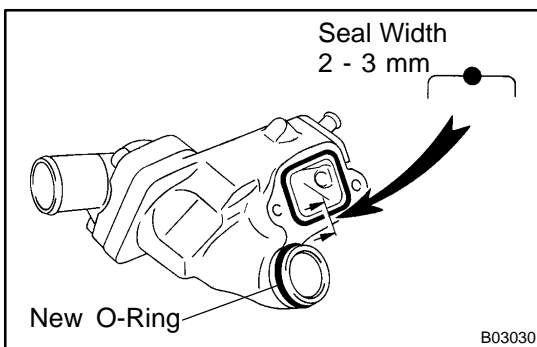

- Apply seal packing to the sealing groove of water inlet housing as shown in the illustration.

Seal packing: Part No. 08826-00100 or equivalent

- ◆ Install a nozzle that has been cut to a 2 - 3 mm (0.08 - 0.12 in.) opening.
 - ◆ Parts must be assembled within 5 minutes of application. Otherwise the material must be removed and reapplied.
 - ◆ Immediately remove nozzle from the tube and reinstall cap.
- Install a new O-ring to the water inlet housing.
 - Apply soapy water on the O-ring.
 - Attach the water inlet housing end to the front water bypass joint hole.

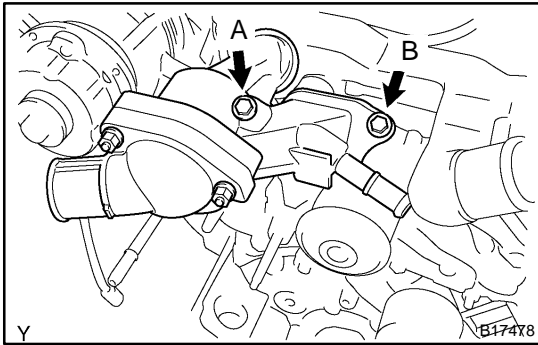

- (f) Install the water inlet and housing assembly with the 2 bolts. Alternately tighten the bolts.

Torque: 18 N·m (185 kgf-cm, 13 ft-lbf)

HINT:

Each bolt length is indicated in the illustration.

Bolt length:

76 mm (3.00 in.) for A

22 mm (0.87 in.) for B

- (g) Connect the water bypass hose to the water inlet housing.

3. **INSTALL NO.2 IDLER PULLEY (See page EM-23)**
4. **INSTALL TIMING BELT (See page EM-23)**
5. **FILL WITH ENGINE COOLANT**
6. **START ENGINE AND CHECK FOR ENGINE COOLANT LEAKS**
7. **RECHECK ENGINE COOLANT LEVEL**

THERMOSTAT COMPONENTS

CO0IU-08

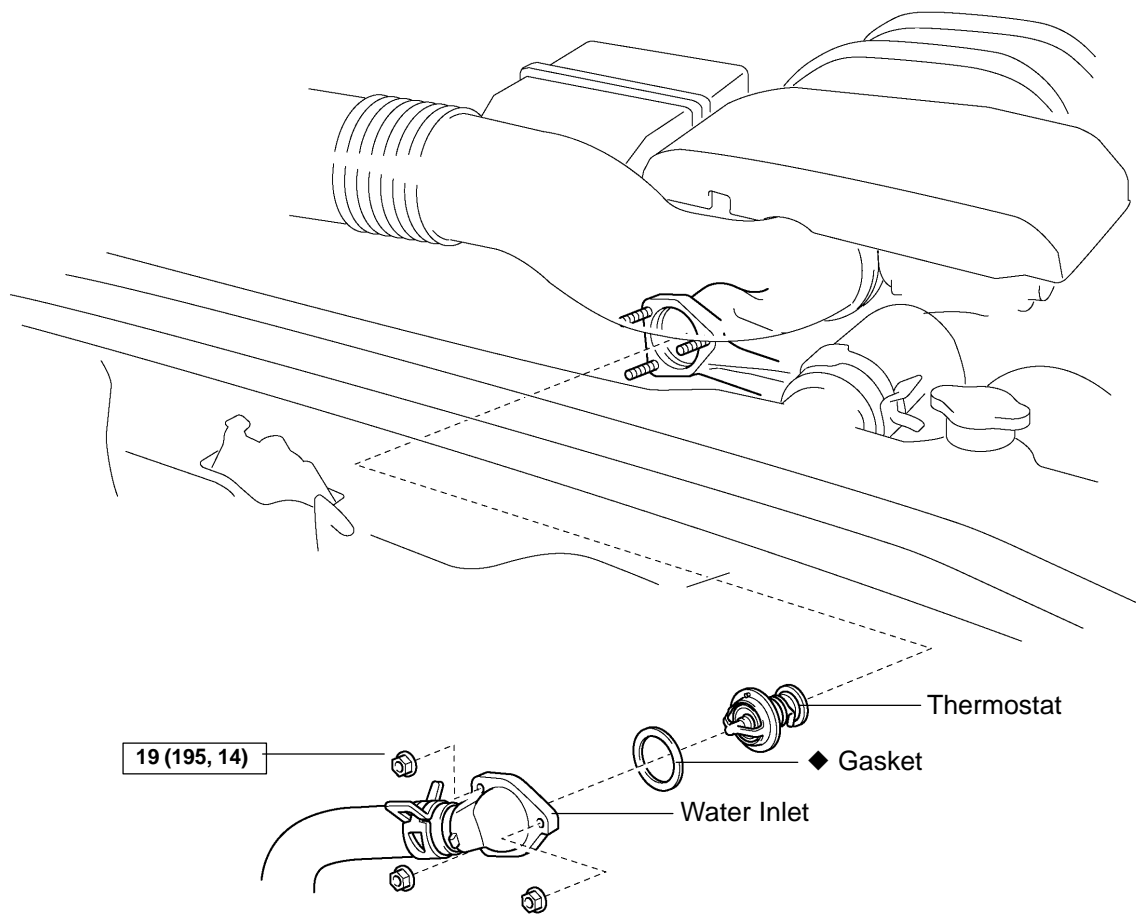

19 (195, 14) : Specified torque
◆ Non-reusable part

D12717

REMOVAL

HINT:

Removal of the thermostat would have an adverse effect, causing a lowering of cooling efficiency. Do not remove the thermostat, even if the engine tends to overheat.

1. DRAIN ENGINE COOLANT

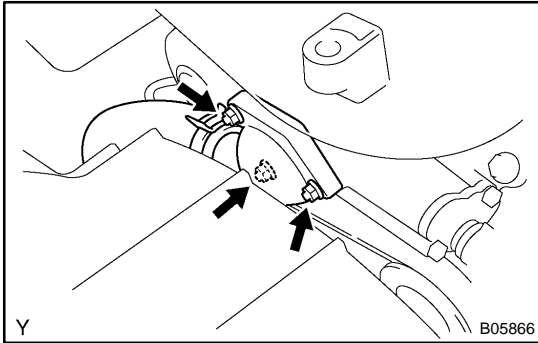

2. DISCONNECT WATER INLET FROM WATER INLET HOUSING

Remove the 3 nuts and disconnect the water inlet from the water inlet housing.

3. REMOVE THERMOSTAT

- (a) Remove the thermostat.
- (b) Remove the gasket from the thermostat.

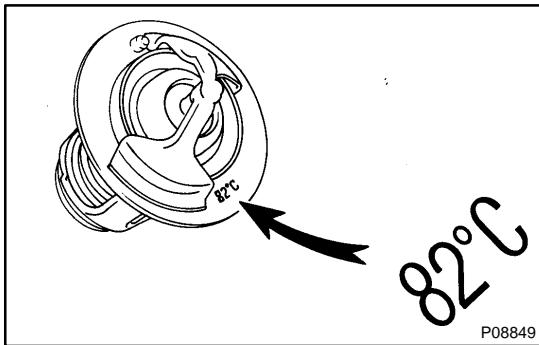

INSPECTION

INSPECT THERMOSTAT

HINT:

The thermostat is numbered with the valve opening temperature.

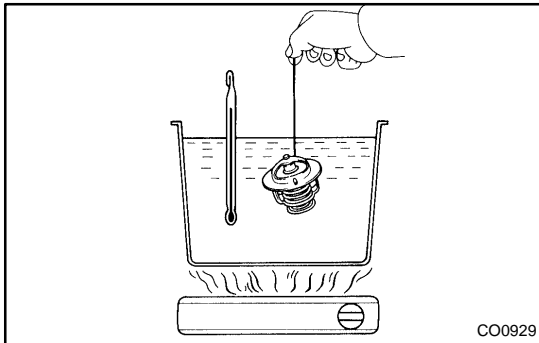

(a) Immerse the thermostat in water and gradually heat the water.

(b) Check the valve opening temperature.

Valve opening temperature: 80 to 84 °C (176 to 183 °F)

If the valve opening temperature is not as specified, replace the thermostat.

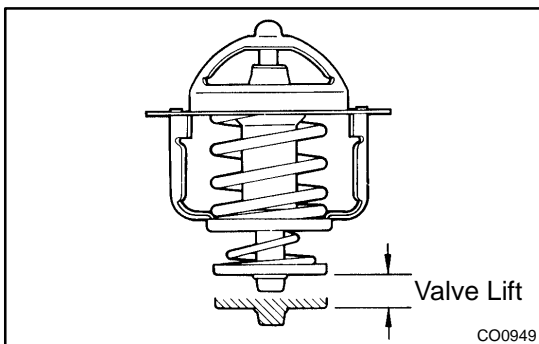

(c) Check the valve lift.

Valve lift: 10 mm (0.39 in.) or more at 95 °C (203 °F)

If the valve lift is not as specified, replace the thermostat.

(d) Check that the valve is fully closed when the thermostat is at low temperatures (below 40 °C (104 °F)).

If not closed, replace the thermostat.

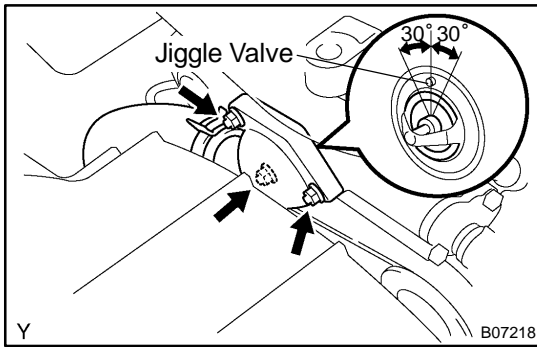

INSTALLATION

1. **PLACE THERMOSTAT IN WATER INLET HOUSING**
 - (a) Install a new gasket to the thermostat.
 - (b) Insert the thermostat into the water inlet housing with the jiggle valve facing straight upward.

HINT:

The jiggle valve may be set within 30° of either side of the prescribed position.

2. **INSTALL WATER INLET**

Install the water inlet with the 3 nuts.

Torque: 19 N·m (195 kgf·cm, 14 ft·lbf)

3. **FILL WITH ENGINE COOLANT**
4. **START ENGINE AND CHECK FOR COOLANT LEAKS**
5. **RECHECK ENGINE COOLANT LEVEL**

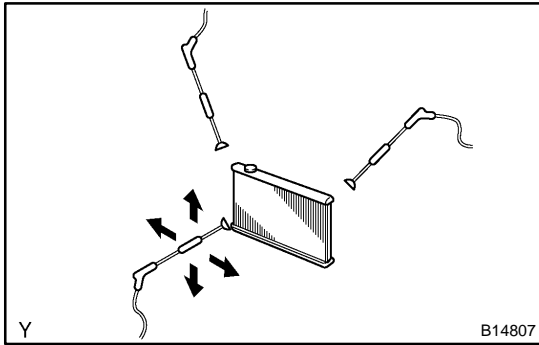

RADIATOR ON-VEHICLE CLEANING

CO1C6-02

INSPECT FINS FOR BLOCKAGE

If fins are clogged, wash them with water or a steam cleaner and dry with compressed air.

NOTICE:

- ◆ If the distance between the steam cleaner and the core is too close, there is a possibility of damaging the fin, so keep the following injection distance.

Injection Pressure	Injection Distance
2,942 to 4,903 kPa (30 to 80 kgf·cm ² , 427 to 711 psi)	300 mm (11.81 in.)
4,903 to 7,845 kPa (50 to 80 kgf·cm ² , 711 to 1,138 psi)	500 mm (19.69 in.)

- ◆ If the fins are bent, straighten them with a screwdriver or pliers.
- ◆ Never apply water directly onto the electronic components.

ON-VEHICLE INSPECTION

1. REMOVE RADIATOR CAP

CAUTION:

To avoid the danger of being burned, do not remove the radiator cap while the engine and radiator are still hot, as fluid and steam can be blown out under pressure.

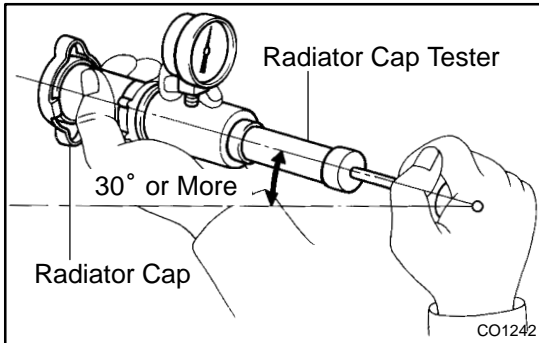

2. INSPECT RADIATOR CAP

NOTICE:

- ◆ If the radiator cap has contaminations, always rinse it with water.
- ◆ Before using a radiator cap tester, wet the relief valve and pressure valve with engine coolant or water.
- ◆ When performing steps (a) and (b) below, keep the tester at an angle of over 30° above the horizontal.

- (a) Using a radiator cap tester, slowly pump the tester and check that air is coming from the vacuum valve.

Pump speed: 1 push/(3 seconds or more)

NOTICE:

Push the pump at a constant speed.

If air is not coming from the vacuum valve, replace the radiator cap.

- (b) Pump the radiator cap tester, and measure the relief valve opening pressure.

Pump speed: 1 push within 1 second

NOTICE:

This pump speed is for the first pump only (in order to close the vacuum valve). After this, the pump speed can be reduced.

Opening pressure:

Standard	74 to 103 kPa (0.75 to 1.05 kgf/cm ² , 10.7 to 14.9 psi)
Minimum	59 kPa (0.6 kgf/cm ² , 8.6 psi)

HINT:

Use the tester's maximum reading as the opening pressure. If the opening pressure is less than minimum, replace the radiator cap.

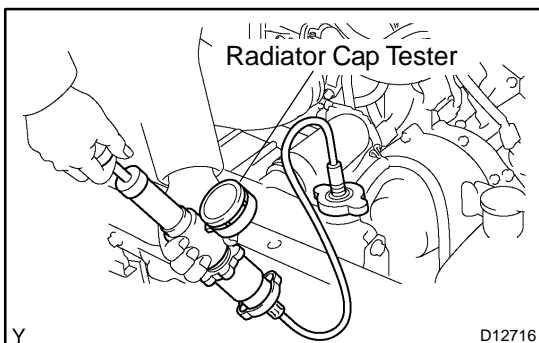

3. INSPECT COOLING SYSTEM FOR LEAKS

- (a) Fill the radiator with coolant and attach a radiator cap tester.
- (b) Warm up the engine.
- (c) Pump it to 118 kPa (1.2 kgf/cm², 17.1 psi), and check that the pressure does not drop.

If the pressure drops, check the hoses, radiator or water pump for leaks. If no external leaks are found, check the heater core, cylinder block and head.

4. REINSTALL RADIATOR CAP

COMPONENTS

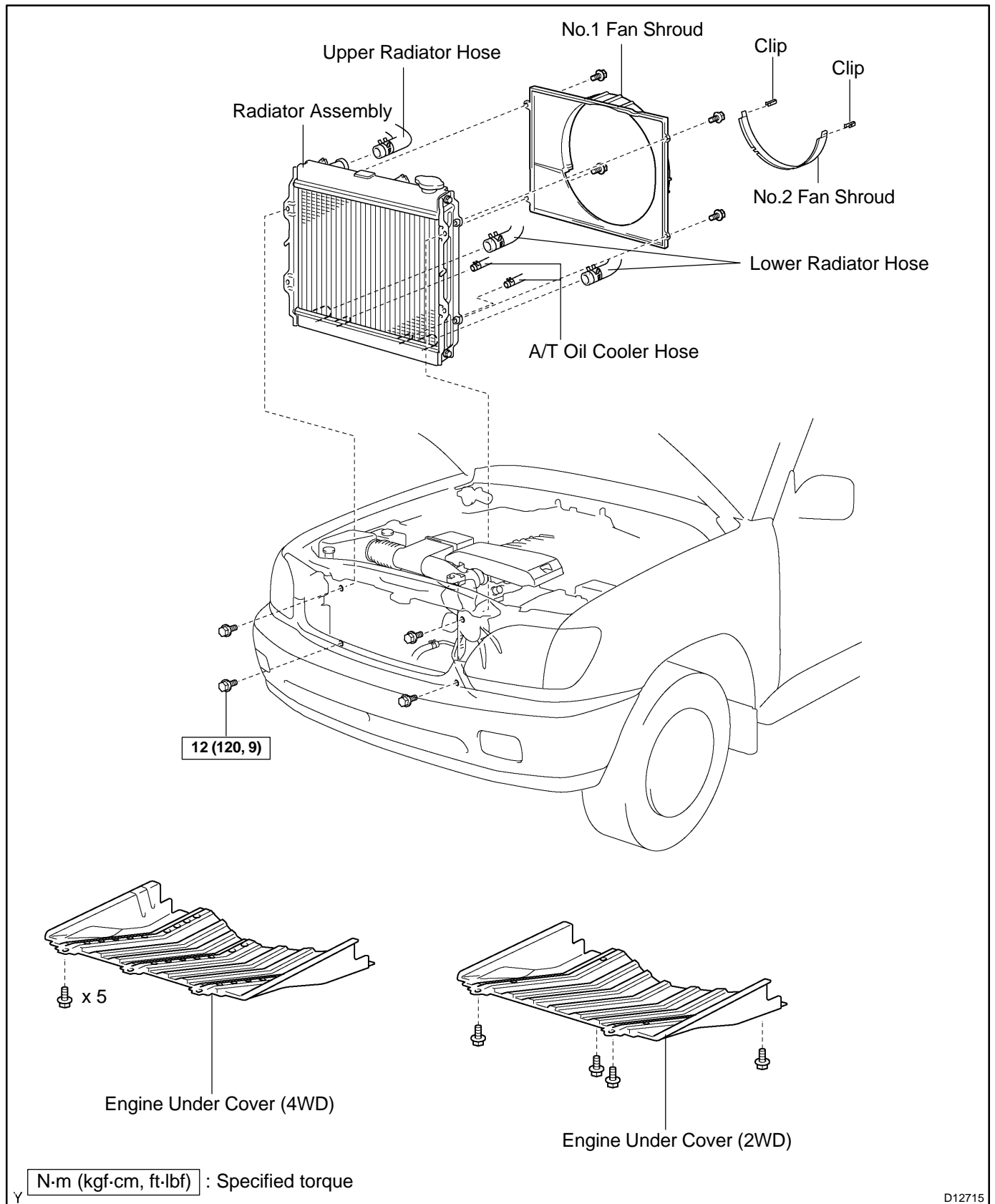

D12715

REMOVAL

1. REMOVE ENGINE UNDER COVER
2. DRAIN ENGINE COOLANT
3. DISCONNECT RADIATOR RESERVOIR HOSE FROM RADIATOR
4. DISCONNECT UPPER RADIATOR HOSE FROM RADIATOR
5. DISCONNECT LOWER RADIATOR HOSE FROM RADIATOR
6. DISCONNECT A/T OIL COOLER HOSES FROM RADIATOR
7. REMOVE NO.2 FAN SHROUD

Remove the 2 clips and No.2 fan shroud.

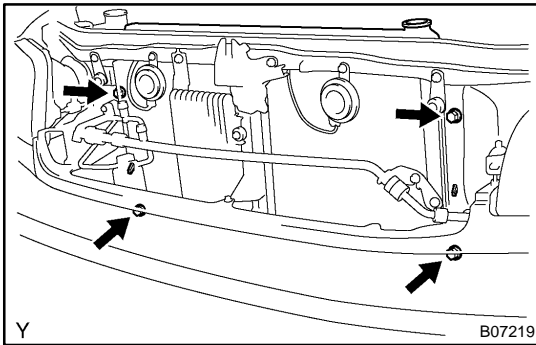

8. REMOVE RADIATOR ASSEMBLY

Remove the 4 bolts and radiator assembly.

9. REMOVE NO.1 FAN SHROUD

Remove the 4 bolts and No.1 fan shroud.

INSTALLATION

1. INSTALL NO.1 FAN SHROUD

Install the No.1 fan shroud with the 4 bolts.

Torque: 5.0 N·m (50 kgf·cm, 44 in.-lbf)

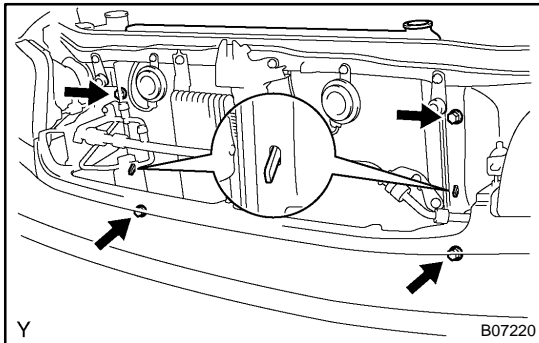

2. INSTALL RADIATOR ASSEMBLY

(a) Set the radiator bracket hooks to the radiator support holes.

(b) Install the 4 bolts.

Torque: 12 N·m (120 N·m, 9 ft-lbf)

3. INSTALL NO.2 FAN SHROUD

Install the No.2 fan shroud with the 2 clips.

4. CONNECT A/T OIL COOLER HOSES TO RADIATOR
5. CONNECT UPPER RADIATOR HOSE TO RADIATOR
6. CONNECT LOWER RADIATOR HOSE TO RADIATOR
7. CONNECT RADIATOR RESERVOIR HOSE TO RADIATOR
8. FILL WITH ENGINE COOLANT
9. START ENGINE AND CHECK FOR ENGINE COOLANT LEAKS
10. RECHECK ENGINE COOLANT LEVEL
11. INSTALL ENGINE UNDER COVER