

DTC	P0125	Insufficient Coolant Temp. for Closed Loop Fuel Control
------------	--------------	--

CIRCUIT DESCRIPTION

To obtain a high purification rate for the CO, HC and NOx components of the exhaust gas, a three-way catalytic converter is used, but for the most efficient use of the three-way catalytic converter, the air-fuel ratio must be precisely controlled so that it is always close to the stoichiometric air-fuel ratio.

The A/F sensor has the characteristic that provides output voltage* approximately proportional to the existing air-fuel ratio. The A/F sensor output voltage* is used to provide feedback for the ECM to control the air-fuel ratio.

By the A/F sensor output, the ECM can determine the deviation amount from the stoichiometric air-fuel ratio and control the proper injection time immediately. If the A/F sensor is malfunctioning, ECM is unable to perform accurate air-fuel ratio control.

The A/F sensor is equipped with a heater which heats the zirconia element. The heater is controlled by the ECM. When the intake air volume is low (the Temperature of the exhaust gas is low), current flows to the heater to heat the sensor for accurate oxygen concentration detection.

*: The voltage value changes at the inside of the ECM only.

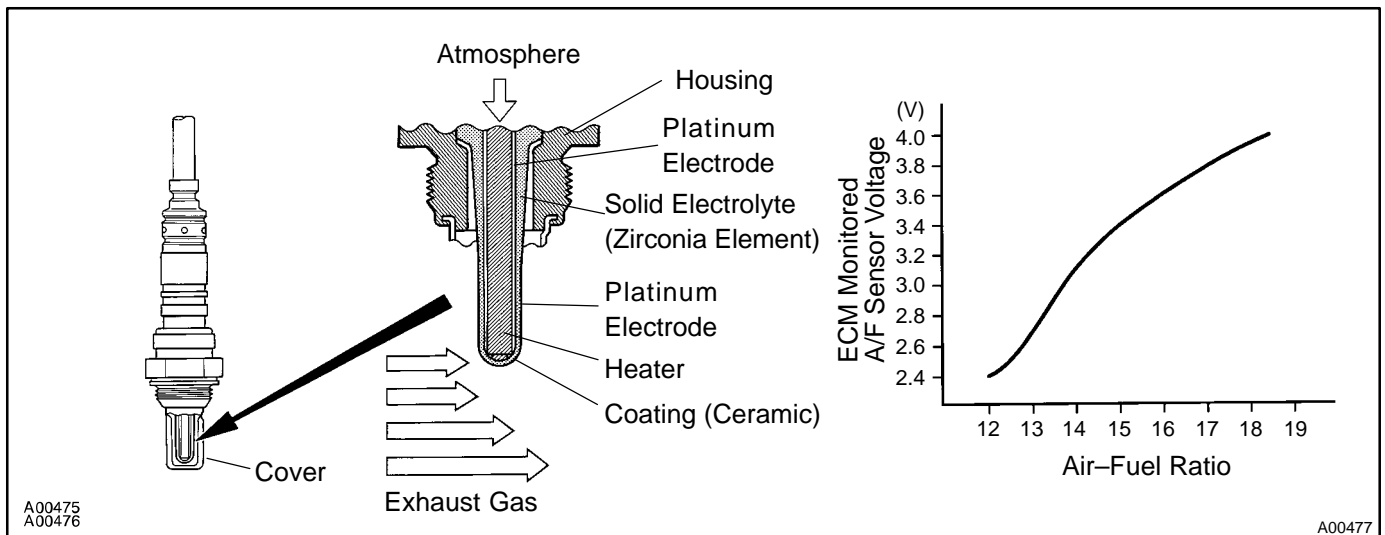

DTC No.	DTC Detecting Condition	Trouble Area
P0125	After engine is warmed up, A/F sensor output* does not change when conditions (a), (b), (c) and (d) continue for at least 1.5 min: *: Output value changes at inside of the ECM only (a) Engine speed: 1,500 rpm or more (b) Vehicle speed: 40 – 100 km/h (25 – 62 mph) (c) Throttle valve is not fully closed (d) 140 sec, or more after starting engine	<ul style="list-style-type: none"> • Open or short in A/F sensor (bank 1, 2 sensor 1) circuit • A/F sensor (bank 1, 2 sensor 1) • Air induction system • Fuel pressure • Injector • Gas leakage on exhaust system • ECM

HINT:

- After confirming DTC P0125, use the OBD II scan tool or LEXUS hand-held tester to confirm voltage output of the A/F sensor (bank 1, 2 sensor 1) from the CURRENT DATA.
- The ECM controls the voltage of the AFR+, AFL+, AFR- and AFL- terminals of the ECM to the fixed voltage. Therefore, it is impossible to confirm the A/F sensor output voltage without the OBDII scan tool or LEXUS hand-held tester.

- OBD II scan tool (excluding LEXUS hand-held tester) displays the one fifth of the A/F sensor output voltage which is displayed on the LEXUS hand-held tester.

WIRING DIAGRAM

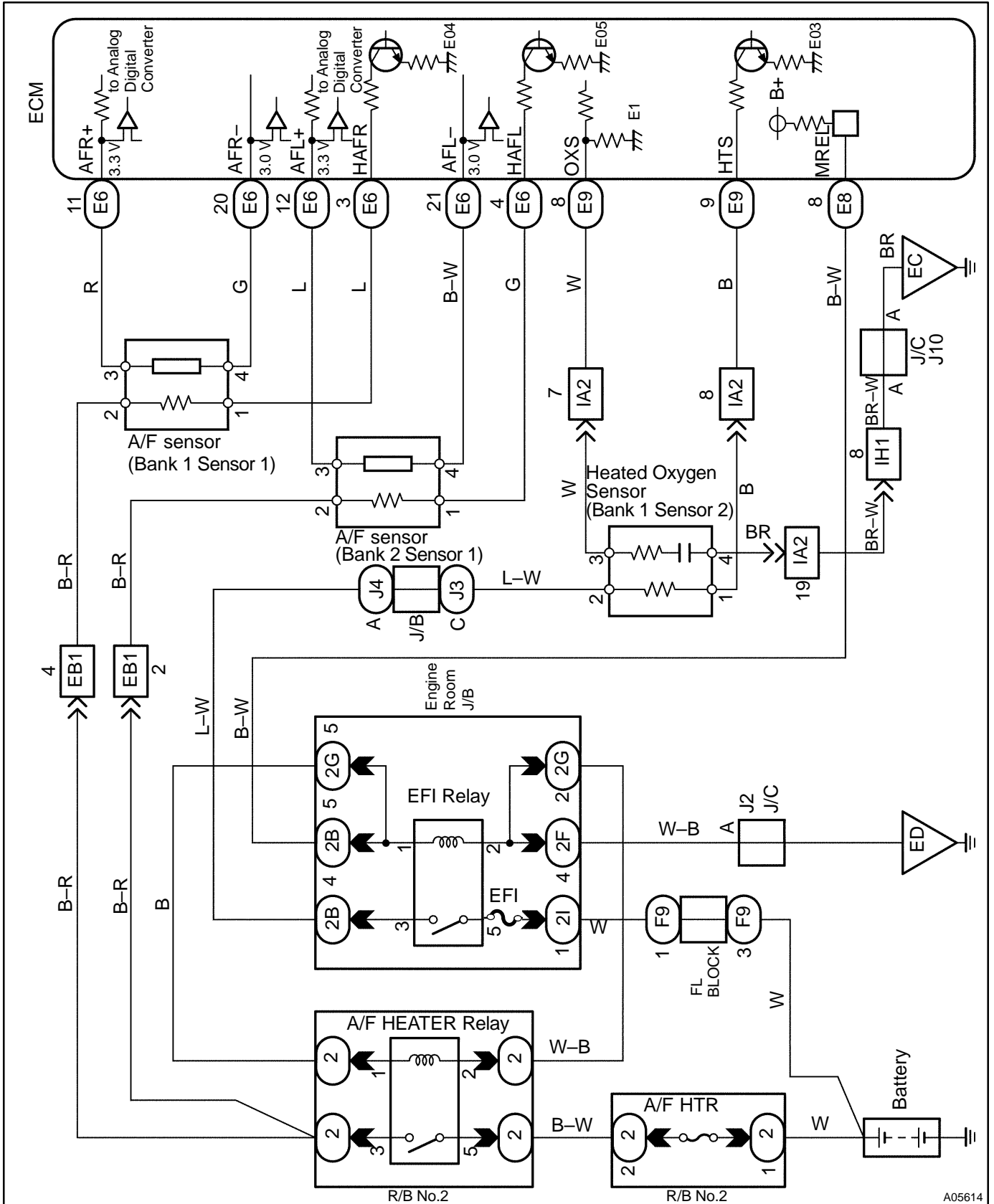

INSPECTION PROCEDURE

HINT:

Read freeze frame data using LEXUS hand-held tester or OBD II scan tool. Because freeze frame records the engine conditions when the malfunction is detected. When troubleshooting, it is useful for determining whether the vehicle was running or stopped, the engine was warmed up or not, the air-fuel ratio was lean or rich, etc. at the time of the malfunction.

1	Are there any other codes (besides DTC P0125) being output?
----------	--

YES	Go to relevant DTC chart.
------------	----------------------------------

NO

2	Connect the OBD II scan tool or LEXUS hand-held tester, and read value for voltage output of A/F sensor (bank 1, 2 sensor 1).
----------	--

PREPARATION:

- (a) Connect the OBD II scan tool or LEXUS hand-held tester to the DLC3.
- (b) Warm up the A/F sensor with the engine speed at 2,500 rpm for approx. 90 sec.

CHECK:

Read the voltage value of the A/F sensor on the screen of OBDII scan tool or LEXUS hand-held tester when you perform all the following conditions.

HINT:

The voltage of the AFR+ or AFL+ terminal of the ECM is fixed at 3.3 V and the voltage of the AFR- or AFL- terminal is fixed at 3.0 V. Therefore, it is impossible to check the A/F sensor output voltage at the terminals (AFR+, AFL+/AFR-, AFL-) of the ECM.

OK:

Condition	A/F Sensor Voltage Value
Engine idling	<ul style="list-style-type: none"> • Not remains at 3.30 V (0.660 V*) • Not remains at 3.8 V (0.76 V*) or more • Not remains at 2.8 V (0.56 V*) or less *: When you use OBD II scan tool (excluding LEXUS hand-held tester)
Engine racing	
Driving at engine speed 1,500 rpm or more and vehicle speed 40 km/h (25 mph) or more, and operate throttle valve open and close	

HINT:

- During fuel enrichment, there is a case that the output voltage of the A/F sensor is below 2.8 V (0.56 V*), it is normal.
- During fuel cut, there is a case that the output voltage of the A/F sensor is above 3.8 V (0.76 V*), it is normal.
- If the output voltage of the A/F sensor remains at 3.30 V (0.660 V*) even after performing all the above conditions, the A/F sensor circuit may be open.
- If the output voltage of the A/F sensor remains at 3.8 V (0.76 V*) or more, or 2.8 V (0.56 V*) or less even after performing all the above conditions, the A/F sensor circuit may be short.

*: When you use the OBD II scan tool (excluding LEXUS hand-held tester).

OK	Go to step 9.
-----------	----------------------

NG

3 Check for open and short in harness and connector between ECM and A/F sensor (bank 1, 2 sensor 1) (See page [IN-34](#)).

NG

Repair or replace harness or connector.

OK

4 Check resistance of A/F sensor heater (bank 1, 2 sensor 1) (See page [SF-75](#)).

NG

Replace A/F sensor.

OK

5 Check air induction system (See page [SF-1](#)).

NG

Repair or replace.

OK

6 Check fuel pressure (See page [SF-5](#)).

NG

Check and repair fuel pump, pressure regulator, fuel pipe line and filter (See page [SF-1](#)).

OK

7 Check injector injection (See page [SF-23](#)).

NG

Replace injector.

OK

8 Check gas leakage on exhaust system.

NG Repair or replace

OK

Replace A/F sensor (bank 1, 2 sensor 1).

9 Perform confirmation driving pattern (See page [DI-107](#)).

Go

10 Is there DTC P0125 being output again?

YES Check and replace ECM (See page [IN-34](#)).

NO

11 Did vehicle runs out of fuel in past?

NO Check for intermittent problems (See page [DI-3](#)).

YES

DTC P0125 is caused by running out of fuel.