

Last Modified: 5-4-2007		1.6 D
Service Category: Vehicle Interior		Section: Heating/Air Conditioning
Model Year: 2007		Model: Tundra Doc ID:
Title: AIR CONDITIONING: AIR CONDITIONING SYSTEM (for Automatic Air Conditioning System): SYSTEM D		

SYSTEM DESCRIPTION

1. GENERAL

(a) The air conditioning system has the following controls:

CONTROL	OUTLINE
Outlet Air Temperature Control	Based on the temperature set by the temperature control switch, the neural network control is based on the input signals from various sensors. The temperature setting for the driver and front passenger are controlled independently of the temperature preferences for the right and left side of the cabin. As a result, the air conditioning system accommodates the driver's and front passenger's preferences.
Blower Control	Controls the blower motor in accordance with the airflow volume that has been calculated based on the input signals from various sensors.
Air Outlet Control	Automatically switches the air outlets in accordance with the outlet mode that has been selected based on the input signals from various sensors. In accordance with the engine coolant temperature, outside air temperature, amount of fog on the windshield, and vehicle speed conditions, this control automatically switches the blower outlet to the front or rear outlet to prevent the windshield from becoming fogged when the outside air temperature is low.
Air Inlet Control	Automatically controls the air inlet control damper to achieve the calculated required outdoor air intake. Drives the servo motor (for air inlet) according to the operation of the air inlet control switch to the RECIRC position.
Compressor Control	Through the calculation of the target evaporator temperature based on various sensor signals, the air conditioning amplifier controls the discharge capacity by regulating the opening extent of the air conditioning compressor. The air conditioning amplifier compares the pulley speed signals, which are transmitted from the air conditioning compressor, with the engine speed signals, which are transmitted by the engine speed sensor. When the air conditioning amplifier determines that the pulley is locked, it turns off the magnetic clutch.
Neural Network Control	This control is capable of effecting complex control by artificially simulating the information processing of living organisms in order to establish a complex input / output relationship that is similar to that of living organisms.
Self-Diagnosis	A DTC (Diagnostic Trouble Code) is stored in the memory when the air conditioning amplifier detects a malfunction in the air conditioning system.



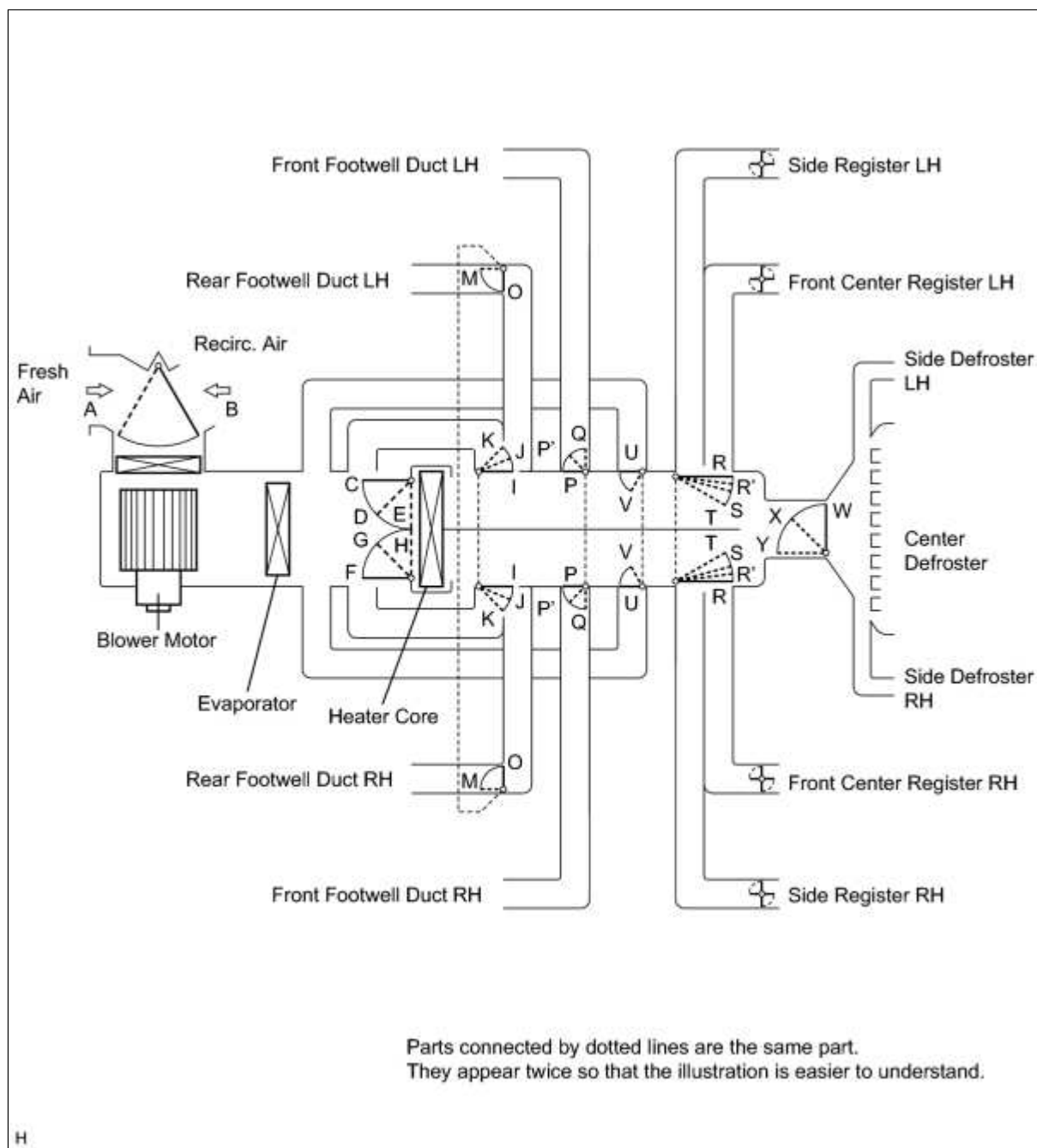

2. MODE POSITION AND DAMPER OPERATION (for Double Cab)

(a) Mode Position and Damper Operation



Functions of Main Dampers:

CONTROL DAMPER	OPERATION POSITION	DAMPER POSITION	OPE
Air Inlet Control Damper	FRESH	B	Brings in fresh air.
	RECIRC	A	Recirculates internal air.
Air Mix Control Damper	MAX COLD to MAX HOT Temperature Setting	C - E F - H I - K	Varies the mixture ratio of fresh air and reci temperature continuously from HOT to COLL
Cool Air Bypass	MAX COLD to MAX HOT	U, V	Cool air blows out of the front center registre

Damper	Temperature Setting		temperature around the head of the occupant
Air Outlet Control Damper	FACE 	O, P, T, W	Air blows out of the front center register, side
	BI-LEVEL 	M, P', S, W	Air mainly blows out of the front center register
	FOOT 	M, Q, R', X	Air mainly blows out of the front and rear footwells from the front and side defrosters, front center
	FOOT / DEF 	M, P', R', Y'	Air mainly blows out of the front and side defrosters and blows out from the front and rear footwell defrosters
	DEF 	O, P, R, Y	Air blows out of the front and side defrosters

HINT:

***1: In multi mode, air blows out of all the air outlets except the front and side defrosters.**



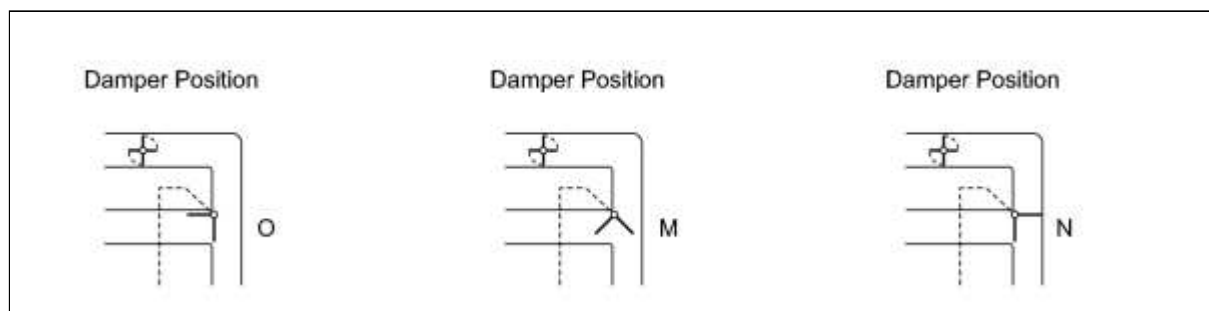
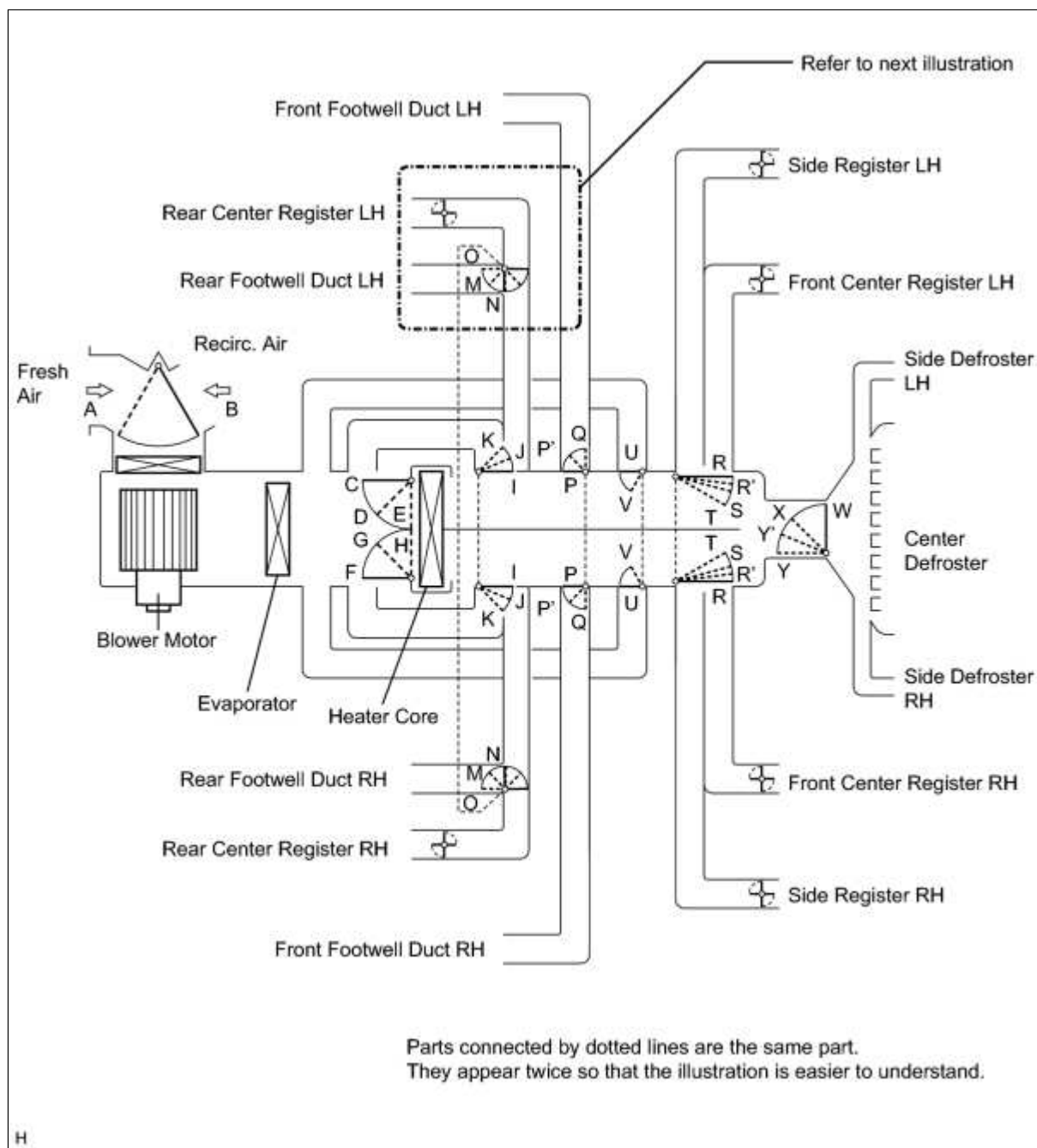

***2: In multi mode, air blows out of all the air outlets.**

3. MODE POSITION AND DAMPER OPERATION (for CrewMax)

(a) Mode Position and Damper Operation



Functions of Main Dampers:

CONTROL DAMPER	OPERATION POSITION	DAMPER POSITION	OPERATION POSITION
Air Inlet Control Damper	FRESH	B	Brings in fresh air.
	RECIRC	A	Recirculates internal air.
Air Mix Control Damper	MAX COLD to MAX HOT Temperature Setting	C - E F - H I - K	Varies the mixture ratio of fresh air and recirculated air continuously from HOT to COLD.
Cool Air Bypass Damper	MAX COLD to MAX HOT Temperature Setting	U, V	Cool air blows out of the front center register at the temperature around the head of the occupant.
Air Outlet Control Damper	FACE 	O, P, T, W	Air blows out of the front center register, side registers, and rear footwell defroster.
	BI-LEVEL 	M, P', S, W	Air mainly blows out of the front center register and side registers.
	FOOT 	M, Q, R', X	Air mainly blows out of the front and rear footwell defrosters, front center register, and side registers.
	FOOT / DEF 	M, P', R', Y'	Air mainly blows out of the front and side defrosters and rear footwell defroster.
	DEF 	N, P, R, Y	Air blows out of the front and side defrosters.

HINT:

***1: In multi mode, air blows out of all the air outlets except the front and side defrosters.**







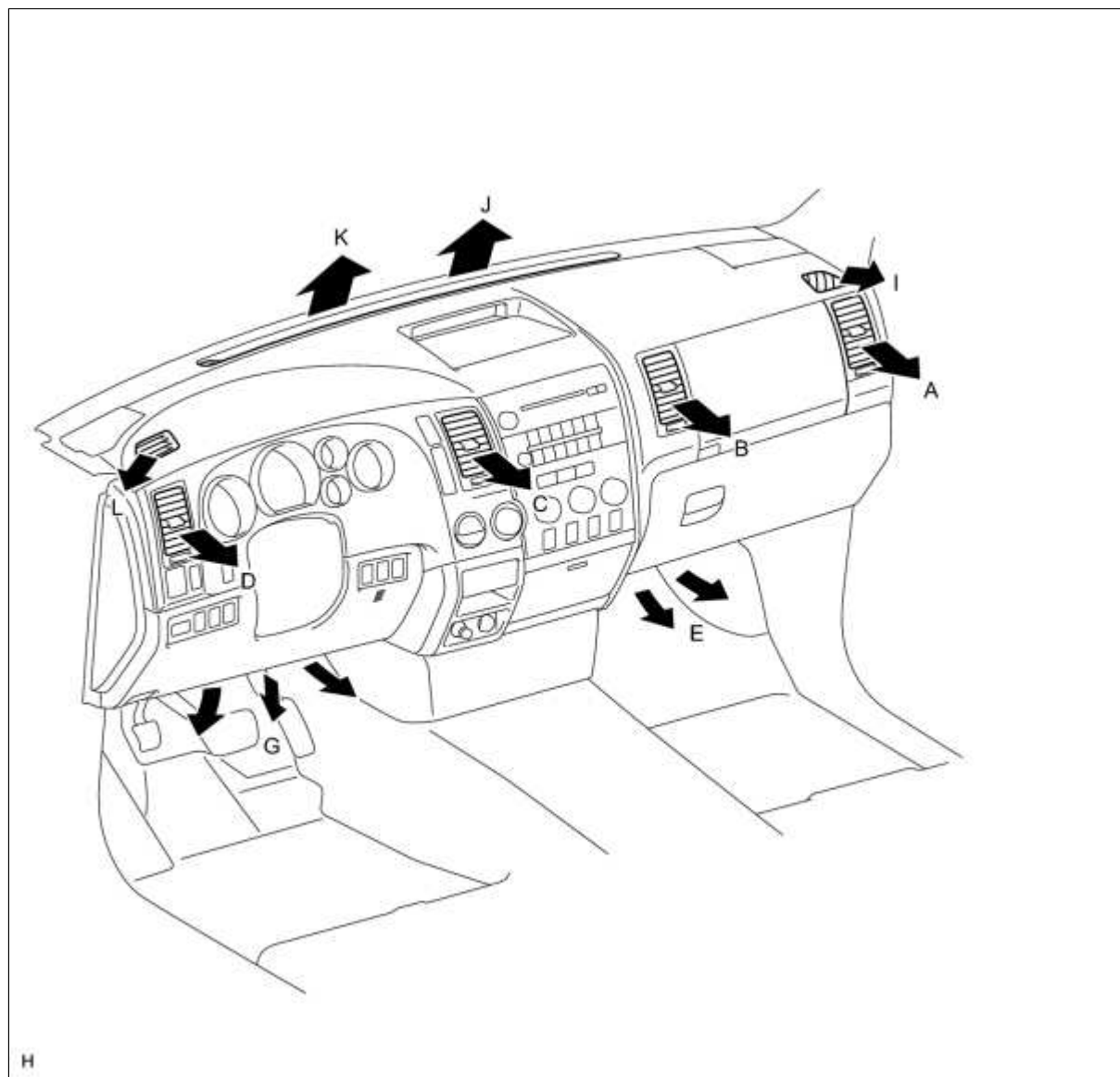

































***2: In multi mode, air blows out of all the air outlets.**

4. AIR OUTLETS AND AIRFLOW VOLUME (for Regular Cab)

(a) Air Outlets and Airflow Volume



INDICATION (MODE)	FACE				FOOT		
	CENTER		SIDE		FRONT		
	DRIVER SIDE	PASSENGER SIDE	DRIVER SIDE	PASSENGER SIDE	DRIVER SIDE	PASSENGER SIDE	
	C	B	D	A	G	E	
 FACE1	<input type="checkbox"/>	<input type="checkbox"/>	<input type="checkbox"/>	<input type="checkbox"/>	-	-	-
 FACE2	<input type="checkbox"/>	<input type="checkbox"/>	<input type="checkbox"/>	<input type="checkbox"/>	<input type="checkbox"/>	<input type="checkbox"/>	-







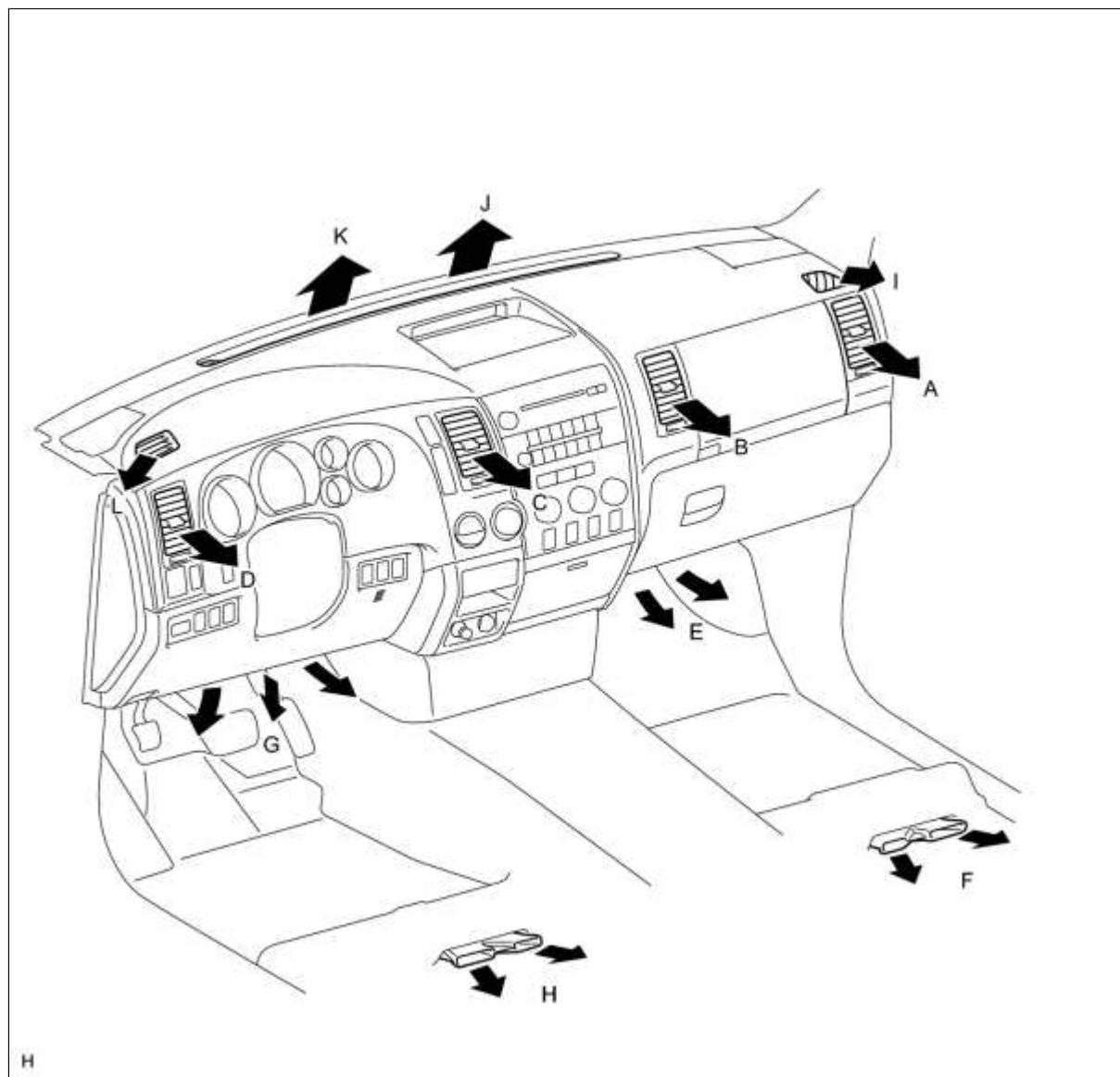







































 B/L							-
 FOOT-D							
 FOOT-R							
 FOOT-F							
 F/D							
 DEF	-	-	-	-	-	-	

5. AIR OUTLETS AND AIRFLOW VOLUME (for Double Cab)

(a) Air Outlets and Airflow Volume



INDICATION (MODE)	FACE				FOOT			
	CENTER		SIDE		FRONT		REAR	
	DRIVER SIDE	PASSENGER SIDE	DRIVER SIDE	PASSENGER SIDE	DRIVER SIDE	PASSENGER SIDE	DRIVER SIDE	PASSENGER SIDE
	C	B	D	A	G	E	H	F
 FACE1	<input type="checkbox"/>	<input type="checkbox"/>	<input type="checkbox"/>	<input type="checkbox"/>	-	-	-	-
 FACE2	<input type="checkbox"/>	<input type="checkbox"/>	<input type="checkbox"/>	<input type="checkbox"/>	<input type="checkbox"/>	<input type="checkbox"/>	<input type="checkbox"/>	<input type="checkbox"/>







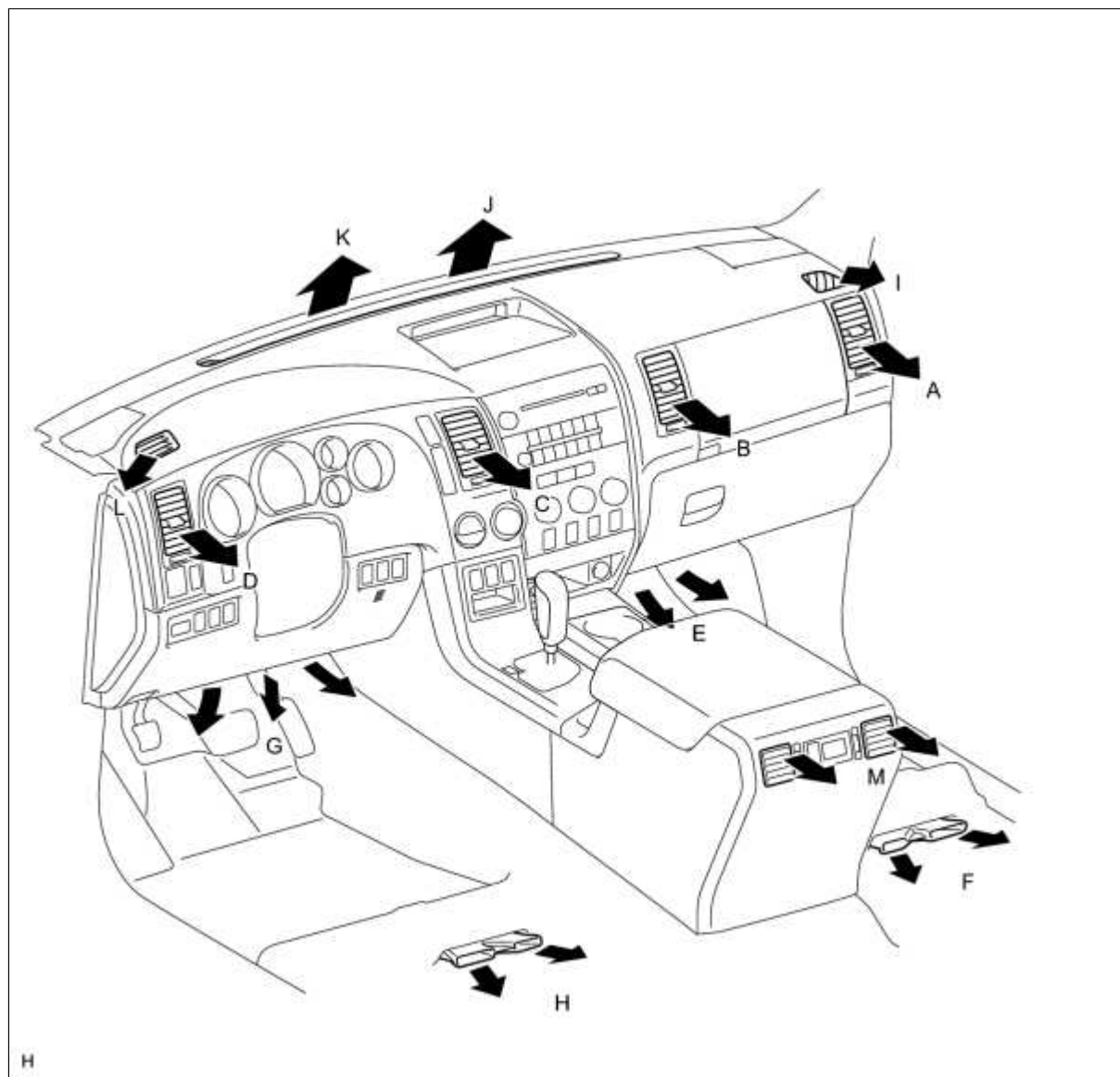











































 B/L								
 FOOT-D								
 FOOT-R								
 FOOT-F								
 F/D								
 DEF	-	-	-	-	-	-	-	-

6. AIR OUTLETS AND AIRFLOW VOLUME (for CrewMax)

(a) Air Outlets and Airflow Volume



INDICATION (MODE)	FACE					FOOT			
	CENTER		SIDE		REAR	FRONT		REAR	
	DRIVER SIDE	PASSENGER SIDE	DRIVER SIDE	PASSENGER SIDE	-	DRIVER SIDE	PASSENGER SIDE	DRIVER SIDE	PASSENGER SIDE
	C	B	D	A	M	G	E	H	F
 FACE1	<input type="checkbox"/>	<input type="checkbox"/>	<input type="checkbox"/>	<input type="checkbox"/>	<input type="checkbox"/>	-	-	-	-
 FACE2	<input type="checkbox"/>	<input type="checkbox"/>	<input type="checkbox"/>	<input type="checkbox"/>	<input type="checkbox"/>	<input type="checkbox"/>	<input type="checkbox"/>	<input type="checkbox"/>	<input type="checkbox"/>

 B/L									
FOOT-D 									
FOOT-R 									
FOOT-F 									
 F/D									
 DEF	-	-	-	-	-	-	-	-	-

